

### Feature:

- ✓ Commercial PA system paging horn speaker with transformer
- ✓ Ideal for outdoor paging and speech use in school, office, hotel and airport
- ✓ Compliant with the EN54-24 EVAC standard.
- ✓ Ceramic connector, fire dome, 95°C fire-resistant cable and thermal fuse.
- ✓ Rated power output 15W/7.5W/3W/1.5W & 8 Ohm
- ✓ Waterproof level of IP66
- ✓ Line input 100V or 70V by cable tail
- ✓ ABS enclosure and stainless metal bracket in white
- ✓ Quick installation by supplied stainless mounting bracket



**EN54-24**

### Specification:

|                    |   |
|--------------------|---|
| Model              | HE-15   |
| Description        | Outdoor Horn Speaker                                      |
| Rated Power Output | 15W/7.5W/3W/1.5W & 8 Ohm                                  |
| Line Input         | 100V or 70V   |
| Frequency Response | 400-8KHz  |
| SPL(@1W/m)         | 110dB   |
| IP Rate            | IP66  |
| Connector          | By speaker cable tail                                     |
| Dimension          | 237×236×175mm   |
| Material           | ABS enclosure and stainless metal bracket in white        |
| Mounting Way       | Quick installation by supplied stainless mounting bracket |
| Weight             | 1.4kg   |

### Dimension and Mounting:

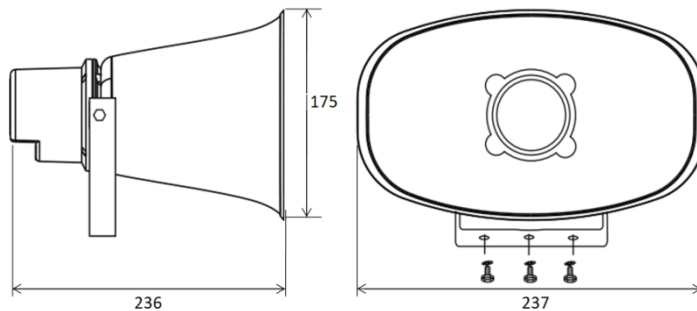

### Frequency Response & SPL Diagram:

