

5.25" 2-Way Wall Mount Speaker ET-530

Feature:

- Commercial public address speaker with transformer
- Ideal for school, office, hotel and airport background music system
- Rated power output 30W at 100V
- 5.25" woofer and 1" silk tweeter two way speaker system
- ABS enclosure, metal grille in black
- Quick installation by supplied stainless mounting bracket
-



Specification:

Model	ET-530
Description	Wall Mount Speaker
Rated Power Output	30W
Line Input	100V or 70V
Frequency Response	100-20KHz
SPL(@1W/m)	89±3dB
Speaker Unit	5.25" woofer and 1" silk tweeter two way speaker system
Dimension	182×162×242mm
Material	ABS enclosure and metal grille in black
Mounting Way	Quick installation by supplied stainless mounting bracket
Net Weight	2.5kg

Side View & Dimension:

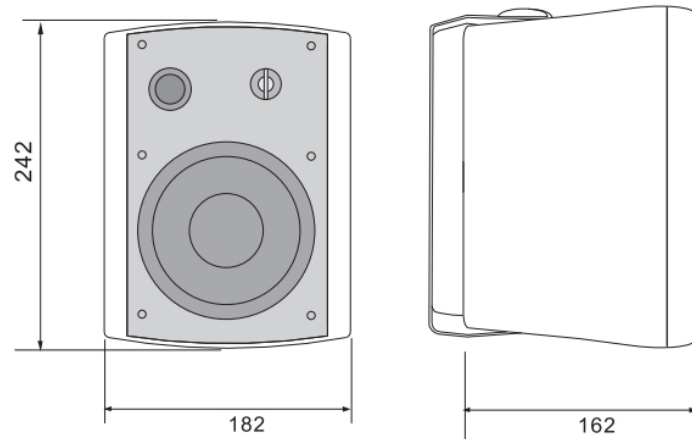

Impedance VS SPL Diagrams:

