



Feature:

- ✓ Commercial PA system wall mount speaker with transformer
- ✓ Ideal for school, office, hotel and airport background music system
- ✓ Compliant with the EN54-24 standards
- ✓ The impact-resistant & UV-resistant ABS plastic housing.
- ✓ IP44 protection level against the risks of environmental influences
- ✓ An integrated thermal fuse, 95°C fire-resistant cable and fire-resistant cone are designed especially for EN54 standards
- ✓ Rated power output 30W/15W/7.5W+8 Ohm
- ✓ 6.5" woofer and 1.5" tweeter two way speaker units
- ✓ Line input 100V or 70V & low impedance 8Ω power selector
- ✓ Quick installation by supplied stainless mounting bracket
- ✓ **ET-630Ds option of white finish**

EN54-24

Specification:

Model	ET-630D
Description	6.5" Two Way Wall Mount Speaker
Rated Power Output	30W/15W/7.5W+8 Ohm
Line Input	100V or 70V
Frequency Response	100-20KHz
SPL(@1W/m)	92dB
Speaker Unit	6.5" woofer and 1.5" tweeter two way speaker units
Dimension	180(W)×170(D)×295(H)mm
Material	ABS enclosure and metal grille in black
Mounting Way	Quick installation by supplied stainless mounting bracket
Weight	2.5kg

Side View & Dimensions:

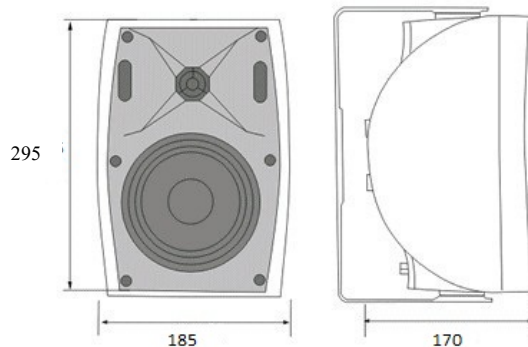

Frequency Response VS SPL Diagram:

