

# 5.25" 2-Way Wall Mount Speaker ET-530TP

## Feature:

- Commercial public address speaker with transformer
- Ideal for school, office, hotel and airport background music system
- Power output 30-15-7.5-3.8W & 8Ω
- 5.25" woofer and 1" silk tweeter two way speaker system
- ABS enclosure, metal grille in black
- Quick installation by supplied stainless mounting bracket
- 



## Specification:

Model	ET-530TP
Description	Wall Mount Speaker
Rated Power Output	30W
Power Taps	30-15-7.5-3.8W & 8Ω
Line Input	100V or 70V
Frequency Response	100-20KHz
SPL(@1W/m)	89±3dB
Speaker Unit	5.25" woofer and 1" silk tweeter two way speaker system
Dimension	182×162×242mm
Material	ABS enclosure and metal grille in black
Mounting Way	Quick installation by supplied stainless mounting bracket
Net Weight	2.5kg

## Side View & Dimension:

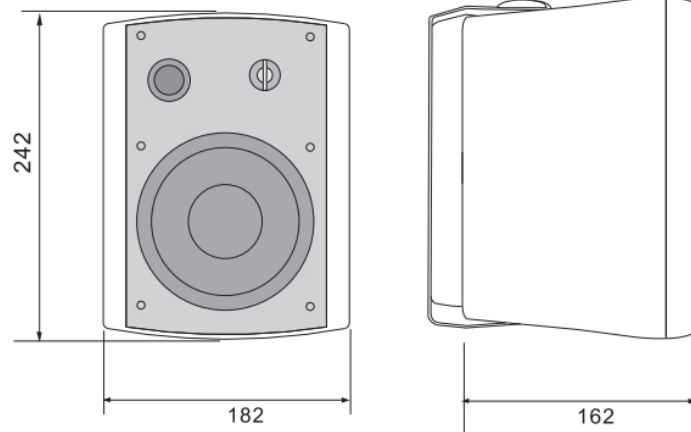
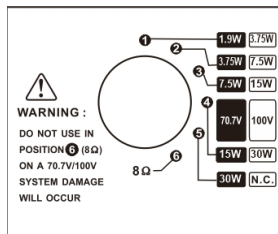

## Impedance VS SPL Diagrams:

